



BUTYNOL®

Roofing

Indian Green Building Council
M E M B E R

ARDEX ENDURA (INDIA) PRIVATE LIMITED

Corporate Office & Regd. Office:
Unit No. 406 & 407, "Brigade Rubix",
No. 20, Yeshwanthapur Hobli, HMT Campus,
Bangalore - 560022. Karnataka, INDIA.
CIN No: U24233KA1997PTC022383
Tel: +91 80 66746500
Fax: +91 80 66746540
Email: customer-care@ardexendura.com
Visit us: www.ardexendura.com

BUTYNOL®

Roofing



DESCRIPTION

A synthetic rubber with properties which resist ageing from heat, sunlight and ozone. It has excellent gas impermeability and toughness and remains flexible at low temperatures.

Butynol is manufactured by combining the petroleum gases isobutylene and isoprene at the extremely low temperature of -100°C . (Rubber Technology–Morton) Butynol is marketed by ARDEX ENDURA as a warranted roofing and tanking product and fixed by their trained and experienced approved Applicators.

BUTYNOL MATERIAL SPECIFICATIONS

Our requirements for long term warranty necessitate that Butynol meets these typical technical requirements:

Specific Gravity to ASTM D297	1.20±0.05
Hardness IRHD to ASTM D1415	65±5
Tensile Strength to ASTM D412	8.3 MPa min
Modulus at 300% elongation to ASTM D412	4.15 MPa min
Elongation at break to ASTM D412	300% min
Heat Ageing (7 days at 115°C)	
Tensile Retention to ASTM D412	70% min
Elongation Retention to ASTM D412	70% min
Tear Strength to ASTM D624	26kN/m
Ozone Resistance to ASTM D1149 (7 days at 40°C in 50pphm ozone)	No visible cracks
Water Permeability to ASTM E96-92 (mg/m ² .h at 35mm Hg)	2.9 at 32°C
(mg/m ² .h at 55.32mm Hg)	15.3 at 40°C

Sample ID	Vapour Flow Resistance (MNs/g)	Mean	Vapour Flow Rate	Mean
D2789 A	7840		0.014	
D2789 B	5880	12414	0.019	0.013
D2789 C	23521		0.005	

Note: Interesting comparable figures for water permeability are – Polythene 156, Asphalt 1830, P.V.C. 4900.

K Values on 1mm Butynol sheeting

K Value (Thermal Conductivity) 7.4×10^3 Cal/cm/sec/deg C.

Conductivity Data on 1mm Butynol sheeting Resistance/m² Ω/m² = 0.6816 on 9.3 volts.

Seam Tape performance

Tests on the seam tape bonding method, by an independent testing laboratory, have shown average values equivalent to 90% of unwelded material.

It is considered impossible for the test methods used to be duplicated in normal service ie. 400% elongation.

BUTYNOL PROTECTS

Against water, moisture vapour, gases, sun, ozone, frost, acids, chemicals and bacteria.

BUTYNOL RESISTS

Tearing, flex cracking, bubbling and abrasion. It is extremely strong, has a long life and is versatile.

BUTYNOL IS PACKAGED

In rolls of nominal 1.4m width and 17.86m long. Each roll is packed in polythene wrapper trademarked BUTYNOL with thickness identified. Coverage 25m² except 2.25mm gauge which is 12m².

Gauges available are:

1.0mm black.	Weight: nominal 30kg
1.5mm black.	Weight: nominal 45kg
2.25mm black.	Weight: nominal 32kg
1.2mm dove grey.	Weight: nominal 30kg
1.5mm all colours.	Weight: nominal 47kg

ADHESIVES AND SOLVENTS

Specially formulated for all Butynol applications. Supplied in 20L steel pails (approx. 20kg). 4 and 1 liter cans.

SEAM TAPE

Uncured Butyl Cold Gum tape supplied by ARDEX ENDURA. Supplied in 50mm x 30.5m rolls (6 to a carton). Used for general lap bonding and laps likely to be subject to periodic ponding.

BUTYNOL SEALANT

Available in tubes for caulking guns.

DETAIL TAPE

A Malleable exterior tape for flashing exterior corners etc. 150mm x 30.5m rolls.

FLASHING TAPE

A malleable tape for moulding in gussets, pipe flashings and awkward situations. Supplied in widths of 50 - 100mm x 5m. Flashing tape must not be left exposed. A Cover strip of Butynol must be applied over flashing tape to finish.

BUTYNOL GAUGES

Standard 1.0mm – For roofs and gutters.
1.2mm – For roofs.
1.5mm – For roofs and walk out decks.
2.25mm – Heavy Duty
 Factory welded panels in all gauges can be custom made.

SUBSTRATE VENTILATION

Substrate ventilation should be used to release moisture trapped under the Butynol. Substrate ventilators are used in conjunction with vent tapes. Tapes should be laid in a grid pattern spaced at 600mm venting to the roof perimeter.

One way substrate ventilators prevent moisture vapour build up and one should be installed every 90 square metres. Not designed to ventilate roof cavities. (Refer Diagram page 2/16)

PLYWOOD TREATMENT

In normal use plywood substrate does not require treatment when used under Butynol. NZS 3602:1995 Table 2B Amendment No. 1 August 1996.

DURABILITY

Butynol when fixed according to ARDEX ENDURA instruction will meet the NZBC requirements of B2.3.1(b) 15 years. Case history of the product in use show applications in excess of 30 years without any additional protection.

EXTERNAL MOISTURE

New Zealand Building Code Acceptable Solution.

E2/AS1 requirements recommend membrane clad roofs have a minimum pitch of 1.5° .

DAMP AND WEATHERPROOFING

The Building Code of Australia Deemed-to-Satisfy Provisions F1.9 and F1.10 are met by Butynol as an acceptable dampproof course. Butynol when used as described in ABSAC Technical Opinion 188 August 1994 complies with the Building Code of Australia Deemed-to-Satisfy Provision F1.7(b) and Acceptable Construction Manual Part 3.8.1.0, or AS 3740 for "Water Proofing of Wet Areas in Buildings".

FIRE RATING

The Butynol roofing system must be considered combustible but may be used on buildings for all purpose groups, subject to the requirements of NZBC Acceptable Solution C/AS1 Part 7, Paragraph 7.11.1

When used for roofs in Purpose Groups SC and SD a non-combustible substrate or timber 18mm thick is acceptable. Refer 7.11.1.

Building Code of Australia allows use in all building types under Specification C1.10, Clause 7(e), except in bush fire prone areas.

BRANZ APPRAISED

BRANZ Appraisal Certificate No 436 (2003)
 Butynol Roofing Membrane has been issued.
 Copy available on request.



PRODUCT WARRANTY

Butynol when laid by a ARDEX ENDURA approved applicator is only covered for up to 20 years if a written material warranty has been requested and provided.

WORKMANSHIP

A warranty for workmanship shall be provided by the approved ARDEX ENDURA applicator. The period of the workmanship warranty shall be determined by the approved applicator.

ADHESIVES AND SOLVENTS FOR USE WITH BUTYNOL

ARDEX ENDURA WA 98 - The Standard contact brushing, spray grade and rolling adhesive for fixing to the substrate and for laps not subject to periodic ponding.

ARDEX WPM 299 Seam Primer - A Water resistant Primer adhesive, used with seam tape for general lap bonding.

Note: Temperature and Humidity

The evaporation of any solvent adhesive system causes a drop in temperature at the interface. At times of high humidity this can result in a micro molecular water layer at the interface which will result in a failure to bond, falsely attributed to Adhesive failure. Fixing should not proceed under these circumstances.

NOTES

1. In cases of extreme absorbency, a priming coat of full strength ARDEX ENDURA WA98 adhesive may assist water shedding and absorption. However, a follow up of full strength adhesive for full bonding should not be proceeded with under four hours, thus allowing full evaporation of solvents absorbed into the substrate. Primers must be time dried not touch dried.
2. As new substrate materials continually appear on the market, consult ARDEX ENDURA Central Technical Service Department for approval of their use with Butynol.
3. Where periodic ponding is likely and on roofs with a slope of 5° or less, ARDEX Seam Tape and ARDEX WPM 299 Seam Primer must be used on all joints.
4. Laps can be formed on roofs with a pitch greater than 5° with normal brush grade substrate ARDEX ENDURA WA 98 adhesive. Laps must be solvent wiped with ARDEX WA 985 solvent prior to applying adhesive. They must however at all times drain dry and have no periodic ponding.
5. Do not use in temperatures less than 6°C.

CAUTION

All Adhesives and Solvents are HIGHLY FLAMMABLE

BUTYNOL SEALANT

DESCRIPTION

Butynol Sealant has been specially designed and formulated for sealing Butynol flashings into chases as found in Building and Construction. Butynol Sealant gives excellent adhesion and sealant to both Butynol Membranes and building substrates. Available in black or grey.

DANGER

Gives off highly flammable vapour. Keep well away from heat, sparks and open flame. Keep closed when not in use.

AVOID BREATHING VAPOUR

Use with adequate air flow.

DIRECTIONS

Once the Butynol Membrane has been fixed into place apply an even bead of Butynol Sealant into the chase, which should be properly prepared by ensuring all surfaces are clean, dry and sound. Tool the sealant bead to ensure there are no voids, gaps or air pockets and that the bead has a neat and flush finish. Cut the cartridge nozzle to give the desired aperture and angle. For best results the sealant should be gunned by pushing the cartridge nozzle forward during application.

TACK FREE TIME

Approx. 24 hours, depending on temperature conditions, can be painted within 4 to 6 days.

FULL CURE TIME

4 - 6 days depending on temperature conditions.

CLEAN UP

Clean tools, etc., with mineral turps.

COLOUR

Black in 375ml tubes.

Also available for Butynol

Seal 'n' Flex Polyurethane
600ml sausages Colours - black and grey
Silaflex MS 300ml tubes Colour - grey

BUTYNOL RUBBER ROOFING SPECIFICATION

1. PRELIMINARY

Refer to the Preliminary and General Clauses of this specification and to the General Conditions of Contract which are equally binding on all trades. This section of the specification shall be read in conjunction with all other sections.

2. SCOPE

This section of the contract consists in general of the provision and laying of all the Butynol rubber, for the roofs, decks, gutters and flashings on the buildings. Refer to Clause 12 hereafter for Extent of Work.

3. WORKMANSHIP

The whole of the work shall be carried out by skilled tradesmen using adequate and proper equipment and methods in accordance with best trade practice, and following the specifications methods and recommendations as laid down by the manufacturers.

4. SUB-CONTRACTORS

The work included in this section of the contract shall be carried out by a firm of roofing experts conversant with and specialising in the supply and fixing of this material and shall be a firm approved by ARDEX ENDURA and the architects.

5. GUARANTEE

The Butynol roofing contractor shall furnish to the main contractor a written guarantee that the Butynol rubber roofing, guttering and flashing together with the adhesives employed will remain watertight and free from any defects that permit the entry of water for a period of twenty (20) years after the installation of the product. Such guarantee shall cover the making good of any defects that may occur from defective materials. The roofing contractor shall obtain from the manufacturer of Butynol rubber sheeting and the adhesives a guarantee covering their materials and shall deliver the guarantee to the Architect. The Butynol Installer shall during the course of this subcontract and at completion make a thorough inspection of the works in order to undertake to furnish a written statement to the main contractor to the effect that all the Butynol roofing, gutters and flashings have been inspected and passed as being fixed strictly in accordance with ARDEX ENDURA recommendations and instructions and best trade practices.

6. MATERIALS

6.1 Butynol Rubber

- A. Shall be 1.0mm thick standard Black Butynol rubber to all roof surfaces, gutters and fascias and walk out decks where membrane is to be overlaid with tiles.
- B. Shall be 1.5mm thick Butynol to all walk out decks.

6.2 Adhesives

Shall be as recommended by ARDEX ENDURA specially formulated for Butynol rubber and suitable for the particular application and the relevant temperature and conditions applicable. Generally the normal adhesive for substrate and lap bonding shall be ARDEX ENDURA WA 98 Adhesive. Primer for lap bonding shall be ARDEX WPM 299 Seam Primer used in conjunction with ARDEX seam tapes. When conditions are experienced that are outside the temperature and/or moisture ranges recommended by the manufacturers for the above standard adhesives work will cease.

6.3 Seam Tapes

Shall be as supplied by ARDEX ENDURA and shall be uncured Butyl Cold Gum tape (Refer ARDEX seam tape). For general lap bonding the tape shall be 50mm in width.

6.4 PVC Tape

All Plywood joints shall be taped with an approved PVC pressure sensitive self adhesive tape of 25mm width or ARDEX ENDURA approved alternative.

7. ROOF DECKINGS

Shall be 1.5mm thick Butynol for all deck surfaces. All decks to which Butynol is to be fixed shall be clean, smooth, dry and free from dirt, grit or sharp objects. All decks, concrete or sheet materials shall be primed with 50/50 ARDEX ENDURA WA 98 and ARDEX WPM 290 solvent. The Butynol roofer shall co-operate with the other trades laying the decking to ensure that the final surface is in first class condition for the laying of the Butynol rubber roofing.

On concrete decks arrange to prime the decks after initial curing again to immediately cover by roofing or the provision of temporary waterproof covers. The Butynol roofer shall check the deck before laying any Butynol to ensure that the surface is completely sound, screw fixed to specifications: screw heads flush, sheets spaced to provide for hydro expansivity, and if plastered concrete that there is no drumminess.

8. LAYING OF BUTYNOL ROOFING

It is the responsibility of the Applicator to ensure that the surface to be covered by the Butynol is in fit and proper condition, suitable in all respects for the laying of the material. Tape all joints in substrate sheets with 25mm wide PVC pressure sensitive tape or ARDEX ENDURA approved alternative. Apply adhesive to the substrate and the underside of the Butynol rubber sheeting by brush, spray or an approved type roller at a spreading rate of generally not less than 2.5 square metres per litre. Leave to tack dry observing the minimum and maximum allowable times set by the adhesive manufacturer, before bonding the two surfaces together. Lay sheeting by drawing back halfway either longitudinally or transversely. Thoroughly roll or work over the surface of the sheet to exclude all air and to obtain a full bond. In general - all Butynol sheeting shall be laid out on the roof to "relax" the sheeting before fixing. A period of at least 20 minutes is usually required. Do not finally position sheeting with a tension exceeding 2%. All sheeting to the roofs shall be laid out as indicated on the roof plan, ie, at across the slope to an even Patter. End laps shall be avoided wherever possible but where necessary to the Architects approval. All roofs and/or gutters shall be "lap bonded" at all joints. Lap bonding shall be with ARDEX Seam Tape and ARDEX Seam Primers.

Bonding Laps with ARDEX Seam Tape and ARDEX WPM 299 Seam Primer

Following laying of the Butynol the laps must be sealed. Roofs with a pitch of less than 5° and all guttering and areas subjected to periodic ponding require special lap bonding.

1. The top lap is positioned and the bottom sheet marked to indicate the edge of the top sheet.
2. The top sheet is folded back.
3. The ARDEX WPM 299 Seam Primer is then applied to the Butynol in the area marked on the bottom sheet and 50mm in from the edge on the top sheet. The ARDEX WPM 299 Seam Primer is applied to the mating surfaces using a synthetic scrubbing pad. Scrubbing pads should be replaced as they become dirty. Allow the primer to become 'dry to the touch'.
4. Position and unroll the 50mm ARDEX Seam Tape along the seam. The edge of the release paper should be aligned to the mark on the bottom membrane sheet.
5. Roll the length of the seam with the release paper still in place.
6. Remove the release paper from the ARDEX Seam Tape by pulling at a 45° angle away from the seam. Keep the release paper low to the roof surface as it is removed.
7. Fold into place the primed edge of the top sheet.
8. Roll the completed seam.

9. TILING OVER BUTYNOL

To direct fix tiles to Butynol, ABA Optima two part adhesive should be used. Ensure the Butynol surface is clean and dry before applying the adhesive. All laps must have seam tape.

10. PROTECTION OF LAID BUTYNOL SHEETING

The Butynol roofing contractor shall ensure that his fixers only work on the Butynol roofing with soft sole shoes. The Butynol roofer shall co-ordinate with the main contractor who shall ensure that any other trades who work over the completed roof wear soft sole shoes.

Upon completion of each area the roofer shall get the main contractor to inspect the area and the main contractor will sign off that the area was free from any defects or damage. It is then the responsibility of the main contractor to ensure the Butynol roofing is in no way damaged by other trades.

11. COMPLETION

On completion of this roofing carefully and thoroughly clean off and remove all scraps and other rubbish from finished surfaces and leave in tidy order with the whole roof waterproof and in first class condition.

12. EXTENT OF WORK

Observe the foregoing specification and supply and lay Butynol rubber sheeting to all roofs, decks, gutters and flashings as shown and detailed on the drawings.

Failure to comply with the above specifications will result in all warranties being null and void.

SUBSTRATE SPECIFICATION

All surfaces to which Butynol is to be fixed shall be clean, smooth, dry and free from sawdust, grit or sharp objects. Plywood must be sanded on one side and free from knots. CD Grade Construction Plywood as specified in NZS 3602:1995 Table 2B Amendment No. 1 August 1996, and in conjunction with Australian/ New Zealand Standard 2269:1994. Sarking should be overlaid with Plywood, giving an ideal laying surface.

For normal conditions the Plywood substrate should be 17.5mm and fixed with 3mm gaps between all sheets, and counter sunk screw fixed to Plywood manufacturer's specifications. Fixing centres: edges 150mm, intermediates 200mm. Note that there may be a requirement for closer screwing of the Plywood substrate to suit the particular situation. Plywood is to be laid with the face grain at right angles to the supports. Where roofs are over damp conditions adhesive fixing should be used with screws. Plywood must have sufficient ventilation. Insufficient ventilation will require treatment in line with NZS 3602:1995 Table 2B Amendment No. 1 August 1996. Refer to Plywood manufacturers for screw specification. Staples and nails are not suitable in any circumstances. NOTE: The use of LOSP (Light Organic Solvent Preservative) treated Plywood or composite boards of any type or density must not be used under Butynol in any circumstances or conditions.

Joins in plywood sheets are to be taped using 25mm Polyethylene tape. Plywood substrates with right angled internal corners should have a triangular fillet 50mm x 50mm screwed to each corner. External corners should be rounded to reduce wear on edges and allow an improved finish. Downpipe outlet holes should be drilled through timber boxed gutters and decks before installation. Butynol must have a 150mm minimum upstand on decks, therefore provision must be made for timber backing. It is important to leave doors and windows out until Butynol has been fixed. A steel trowel finish is required on all concrete surfaces. New concrete must be cured a minimum of 28 days prior to Butynol installation.

If any patch or filling of substrate is required it is best to use a fibreglass material, or an ARDEX ENDURA floor laying compound to resist the heat absorbed through the black Butynol, so it will not break up causing bubbling.

Pumice surfaces are not recommended as a suitable substrate for Butynol. Light weight concrete surfaces require saw cut grooves for venting purposes.

On large areas of Plywood, sheets may be preprimed before being screwed to roof framing, to speed the application of the Butynol. Temperature on the substrate surface must not drop below 6°C for adhesives to go off.

LAYING SPECIFICATION

The Sub contractor for the work called for in this trade will be a Company or Person Accredited by ARDEX ENDURA. The Accredited Applicator (hereafter called the Applicator) shall examine all drawings and provide for the flashing, caulking and sealing of all vents, stacks and pipes penetrating the roofing membrane. Also all flashings at walls, parapets, verges, gutters etc., unless otherwise instructed in the specifications.

The surface to which Butynol is to be fixed shall be clean, smooth, dry and free from sawdust, grit or sharp objects. Membrane laying shall not start until defects have been corrected.

It is the responsibility of the Applicator to ensure that the surface to be covered by the Butynol is in fit and proper condition, suitable in all respects for the laying of the material.

On completion the Applicator will provide the owner with a Workmanship Warranty and obtain from ARDEX ENDURA a Materials Warranty.

Failure to comply with the above specifications will result in all warranties being null and void.

LAYING THE BUTYNOL

Before applying the Butynol, it shall be unrolled for twenty minutes to relieve stresses induced by manufacture and storage. The Butynol sheet shall be set out in the exact position in which it will be finally required and while it is held in place, it shall be folded back lengthwise to expose half the underside. To the now exposed underside and the area of roof also left exposed, apply an even coat of ARDEX ENDURA WA 98 Adhesive. When the adhesive has become touch dry, work the sheet back into its original position avoiding wrinkles and the inclusion of air bubbles. Repeat the process with the other half of the sheet and when completed, roll the whole sheet with hand press rollers or the like. When applying the next sheet, it shall be lapped over the first sheet by 50mm. All turn ups and downs shall be neatly formed and cut to a straight line if necessary. Butynol shall not be laid under tension. When the whole area has been covered or as work progresses, the applicator has to seal the laps.

BUTYNOL LAYING METHOD

STEP 1

Accurately place sheet. Mark spacing with chalk line.

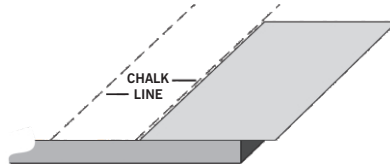

STEP 2

Fold back half sheet. Apply adhesive to both faces.

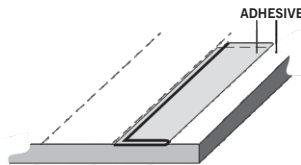

STEP 3

After flash off, fold membrane into place. Roll thoroughly.

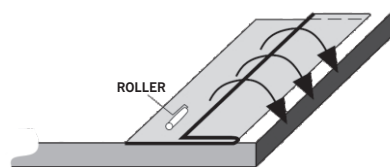

STEP 4

Treat 2nd half of Butynol similarly.

BONDING THE LAPS

Roofs with a pitch of less than 5°, all coloured membranes and all guttering and areas subjected to periodic ponding require special lap bonding.

All coloured membranes, irrespective of pitch require special lap bonding.

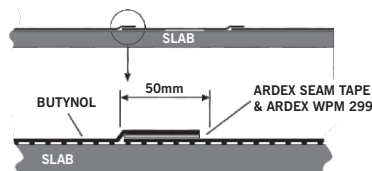

1. The top lap is positioned and the bottom sheet marked to indicate the edge of the top sheet.
2. The top sheet is folded back.
3. The ARDEX WPM 299 Seam Primer is then applied to the Butynol in Butynol Guttering the area marked on the bottom sheet and 50mm in from the edge on the top sheet. The ARDEX WPM 299 Seam Primer is applied to the mating surfaces using a synthetic scrubbing pad. Scrubbing pads should be replaced as they become dirty. Allow the primer to become 'touch dry'.

4. Position and unroll the 50mm ARDEX Seam Tape along the seam. The edge of the seam tape should be aligned to the mark on the bottom membrane sheet. The see through film makes this very simple.
5. Roll the length of the seam with backing film still in place.
6. Remove the backing film from the ARDEX Seam Tape by pulling at a 45° angle away from the seam. Keep the release paper low to the roof surface as it is removed.
7. Fold into place the primed edge of the top sheet.
8. Roll the completed seam.

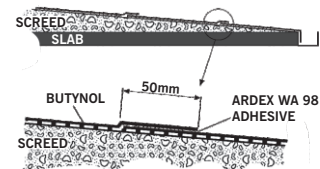

Black Butynol and roofs with minimum pitch of 5° and sufficient fall to prevent periodic ponding may be formed using the sheet bonding adhesive ARDEX ENDURA WA 98. All laps must be wiped with ARDEX WA 290 solvent prior to bonding.

FORMING LAPS FOR GUTTERS

Laps are most important in gutter work and should be and formed using ARDEX seam tape and ARDEX WPM 299.

All internal boxed gutters can be easily formed to any shape or size using Butynol over any specified substrate.

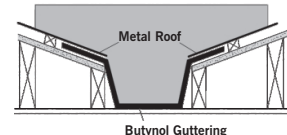
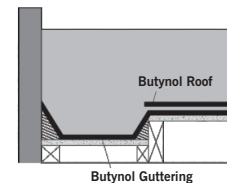

CROSS SECTION OF DROPPER

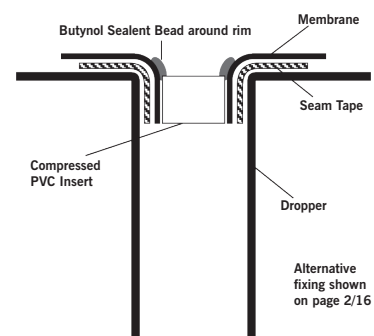

CROSS SECTION OF RAINHEAD

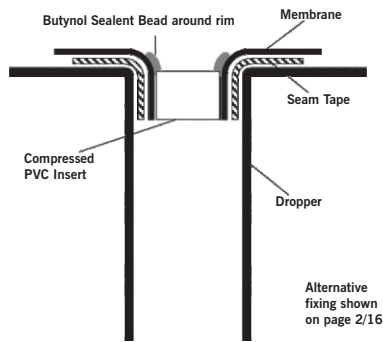

RECOMMENDED BATTEN PROFILE

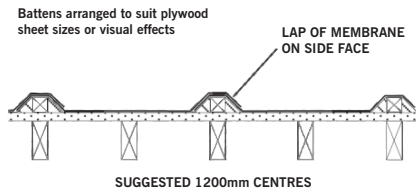
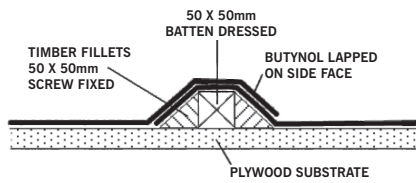

Example of a 1400mm sheet of ARDEX ENDURA BUTYNOL dressed over battens at 1200mm centres

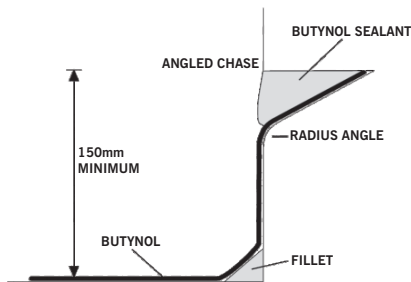

BUTYNOL is glued into angled chase and finished with Butynol Sealant.

FLASHING INTO CONCRETE WALLS EXTERNAL CORNERS

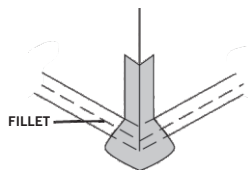

Step 1

Bond 100mm flashing or detail tape to corner as shown

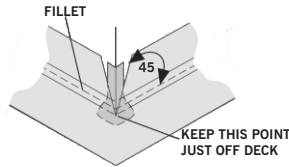

Step 2

Bond BUTYNOL to deck and up wall 150mm minimum. Cut sheet from corner at 45° as shown.

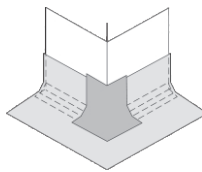

Step 3

Cover corner point with layer of detail tape.

NOTE: Fillets must be used on all internal corners.

INTERNAL CORNERS

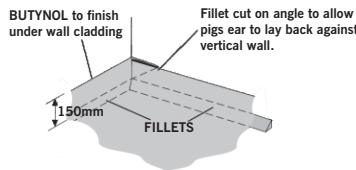

Step 1

Without cutting BUTYNOL simply fold a 'pig's ear' corner as shown. The angle fold should be behind the main sheet.

NOTE: Fillets must be used on all internal corners.

FLASHING - EXISTING PIPES

Step 1

Under flash pipe with 100mm BUTYNOL flashing tape.

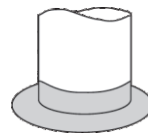

Step 2

Bond BUTYNOL to 100mm past pipe.

N.B. When flashing black BUTYNOL use black detail tape.

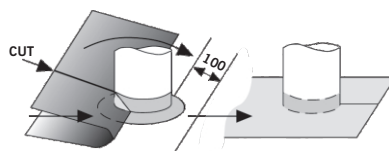

Step 3

Bond continuation of BUTYNOL to overlap base sheet and beyond pipe 100mm.

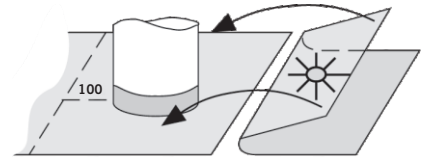

Step 4

Apply another collar of flashing tape, then bond final 70mm cover strip. DO NOT STRETCH STRIP.

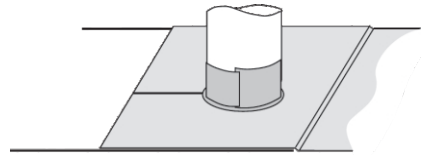

N.B. Flashing Tape MUST NOT be left exposed. Cover strip must be BUTYNOL. When detail tape is used a cover strip of BUTYNOL is not required.

FLASHING - NEW PIPE

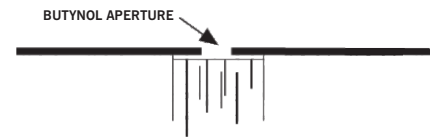

Step 1

Pipe is raised through smaller diameter hole in BUTYNOL, forcing edge upwards to create upstand

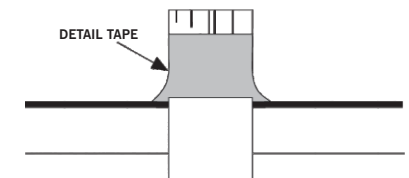
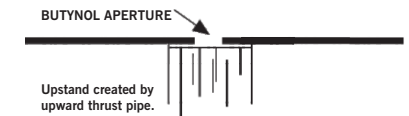

Step 2

After pulling pipe down approximately 1 cm to sharpen corner, tape upstanding BUTYNOL to pipe using ARDEX ENDURA WA 98 Adhesive and detail tape. Upstand may be mechanically secured using a steel band.

N.B. If flashing tape is used it MUST NOT be left exposed. A cover strip of BUTYNOL must be applied over the flashing tape to finish.

TAPING SUBSTRATE SHEET

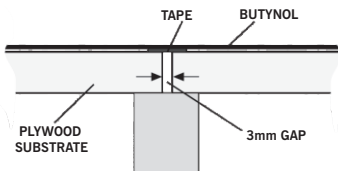

All joints between substrate sheets of Plywood should be taped to prevent stressing of the BUTYNOL in case of marked timber movement.

BOXED GUTTER AND PARAPET DOWNTURN

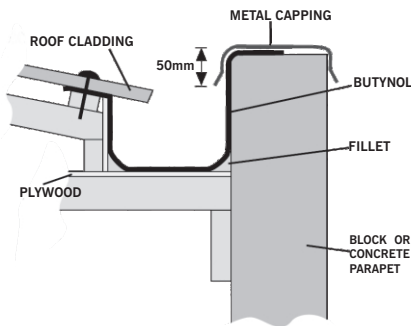

FORMING DOWNTURN IN GUTTER FOR CIRCULAR DOWNPIPE

Cut P.V.C. pipe should be compressed into smaller diameter, then coated with ARDEX ENDURA WA 98 Butynol Adhesive and inserted in Downpipe finishing just below flush. Finished with a bead of Butynol Sealant.

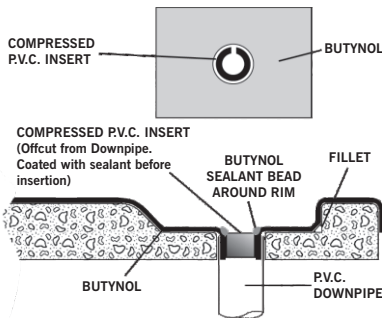

FINISHING OVER A GUTTER

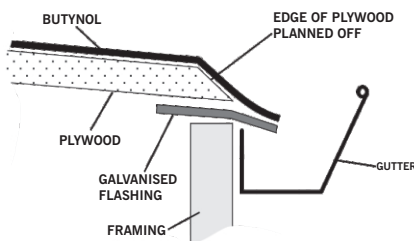

INTERNAL ROOF DRAIN

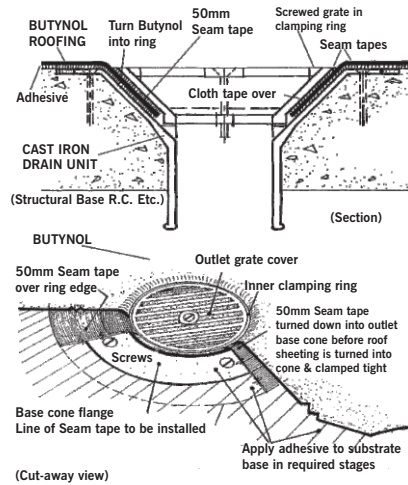

ONE WAY SUBSTRATE VENTILATOR PVC OR ALUMINIUM

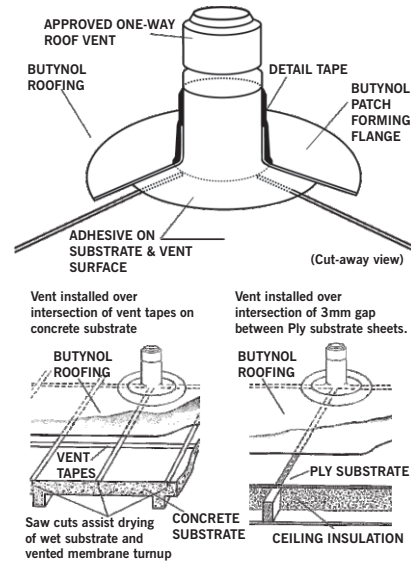

TYPICAL IRMA ROOF DETAIL

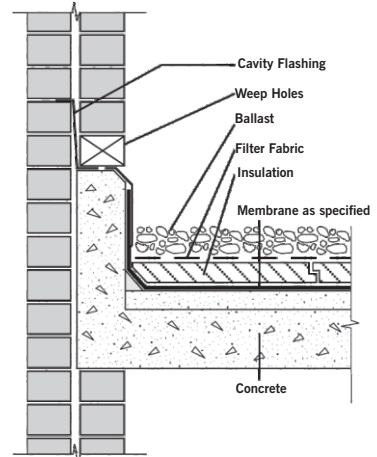
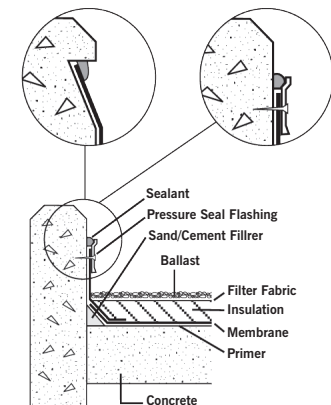

IRMA ROOF OVERFLOW

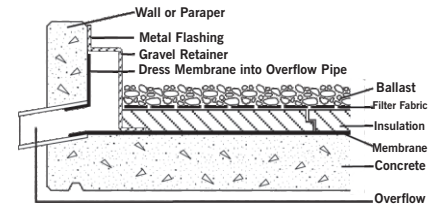

IRMA ROOFOUTLET & GRAVEL RETAINER

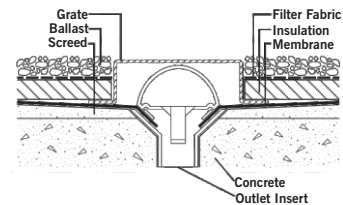

Loose Laid Application of Butynol Roofing

Materials used shall be as previously specified. When the surface is suitably prepared a large fully vulcanised Butynol sheet or sheets can be unrolled and spread over the prepared area and allowed to remain in this position for approximately one hour to relieve stresses induced by manufacture and storage. If necessary for ease of handling, these sheets can be supplied in varying sizes and vulcanised on site using an ARDEX vulcanising machine or using seam tape with ARDEX WPM 299 seam primer.

The Butynol sheet shall be set out in the exact position in which it will be finally required and whilst it is held firmly in place it shall be folded back at least one metre from the roof's surrounding parapet or wall to allow the application of adhesive to that area of the exposed substrate.

ARDEX ENDURA WA 98 Adhesive may be applied to the substrate and the corresponding area of BUTYNOL sheeting which may then, when the adhesive is touch dry, be worked back into its required position avoiding wrinkles and the inclusion of air bubbles.

Upon completion of the detail work, parapets, drains and rainheads etc a layer of rounded gravel 30 - 40mm should be applied up to 50mm deep, over a layer of Geo Textile Fabric for protection of the Butynol sheet.

Care must be taken at outlets to ensure the ballast cannot enter or cause a blockage that prevents rainwater from leaving the roof area. Maintenance paths should be created to air-conditioning or roof plant with concrete tiles.

Effects on the membrane in areas of high wind can be eliminated by stabilising the ballast with cement. Dry cement should be broadcast over the 30 - 40mm gravel with a broad mouth shovel and left to hydrate or lightly sprayed with water to set off.

If possible a water test should be carried out prior to the application of ballast.

Note: Minimum pitch 1.5° to comply.

SCUPPER OUTLET

